



# Heyco-Flex™ III Liquid Tight Fittings

## Straight-Thru, NPT Hubs

FITS CONDUIT/TUBING TRADE SIZE	PART NO.	DESCRIPTION	THREAD SIZE	PART DIMENSIONS									
				A		B		C		D		E	
				Clearance Hole	Max O.A. Length	Thread Length	Wrenching Nut Thk.	Wrenching Flats					
				in.	mm.	in.	mm.	in.	mm.	in.	mm.	in.	mm.
1/2	9147	HF3C 1/2	1/2 NPT	.875	22,3	1.095	27,8	.63	16,0	.20	5,1	1.18	30,0
3/4	9148	HF3C 3/4	3/4 NPT	1.109	28,2	1.215	30,9	.63	16,0	.20	5,1	1.36	34,5

- For use with Heyco-Flex III Tubing.
- Resists salt water, weak acids, gasoline, alcohol, oil, grease, and common solvents. This feature is not assessed by UL certification or testing.
- Easy, permanent assembly between the tubing and fittings: push the tubing over the fitting ferrule until the tubing "clicks" into place.
- Flame retardant, won't burn.
- Nontoxic and UV resistant.
- Locknuts included with fittings.
- For use in both wet and dry applications.
- Use of sealing washer may be required for a complete liquid tight system with a non-threaded mounting hole. See page 1-13.
- Rated for Type 3R applications.
- Lightweight and lower installed cost.
- Suitable for use in high vibration or flexing applications (automotive equipment, fiber optics, computer and peripherals, lab equipment, robotics, etc.).
- Quick and easy installation.

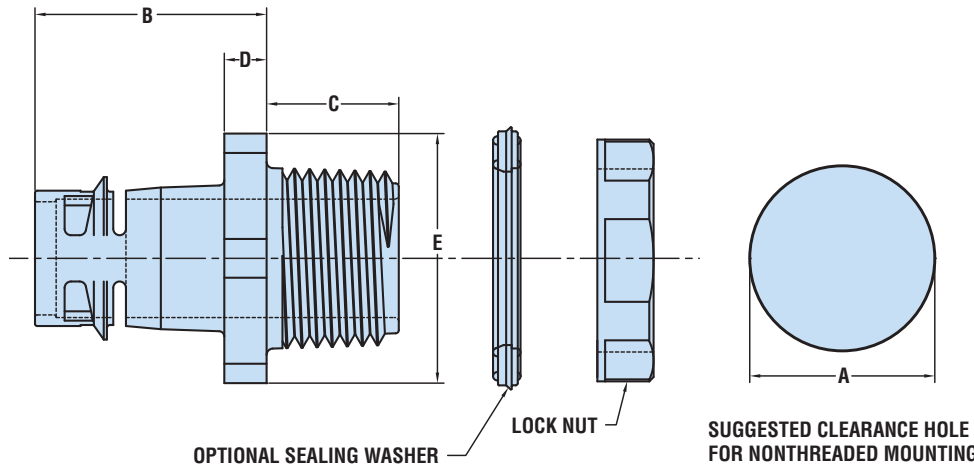

Material	6/6 Nylon
Certifications	Recognized under Underwriters Laboratories File #121095 Certified to both Canadian and U.S. Requirements
Flammability Rating	94V-2
Material Temperature Index	257° (125°C)–Maximum temperature on part not to exceed 221°F (105°C)
Ingress Protection	

*Quick Specs*