

MAXIMUM SOLUTIONS

Press-fit PCB Pins for Plated Through-Holes

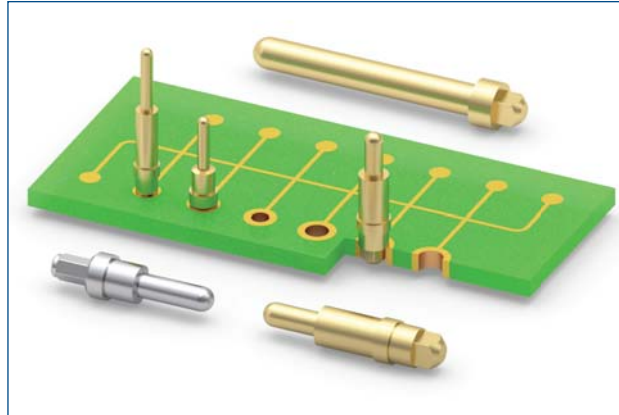

Mill-Max is adding to its diverse mix of press-fit pins with six new offerings designed for applications where mechanical strength and/or power delivery are essential. These new PCB pins feature multi-faceted (polygon) geometries and are suitable for solderless PCB termination or for direct soldering to the board for those situations requiring it.

When these pins are pressed into a plated through-hole the points (the major or circumscribed diameter) of the polygon are set or imbedded in the hole while the flat sides of the feature (minor or inscribed diameter) provide relief, allowing the remainder of the plated through-hole barrel to remain intact. The result is internal board layers are not disconnected when the pin is pressed in. With a properly specified hole size, the polygon shaped press-fit feature will allow the pin to be secured in the hole while maintaining continuity throughout all the layers of the PCB.

Mill-Max employs its machining expertise to manufacture either square or hexagon shaped press-fit features to suit a variety of hole sizes and assembly requirements. Square press-fit features normally leave a larger gap between the flat side of the feature and the hole, useful for solder flow and venting of gasses, while a hexagon feature will provide more interference and greater retention.

(1/17 -- PR673)

Mill-Max Mfg. Corp. • 190 Pine Hollow Road, Oyster Bay, NY 11771
516-922-6000 • Fax: 516-922-9253 • www.mill-max.com



Part #	Pin Dia. (in)	Press-fit Diameter (in) (+/- .0005")	Press-fit Shape	Vent Location	Material
8237-0	.060	.090	Square	None	Brass
5920-0	.080	.0852	Square	None	Brass
6025-0	.040	.067	Hexagon	Pin side	Brass
6035-0	.061	.067	Hexagon	Pin side	Brass
6834-0	.040	.050	Square	Press-fit side	Brass
6835-0	.080	.091	Square	Press-fit side	Tellurium Copper

The pins featured here are often used in applications with more demanding mechanical/ electrical requirements such as power supplies, power converters and any device subject to blind mating or rough handling. They are typically staked into a PCB at the press-fit end and either soldered or plugged in at the pin end. The smallest pin diameter in the group is .040" while the largest is at .080", typical sizes for DC-DC converters. These pins are suitable for high current applications, the limits of which depend on the temperature requirements and heat sinking abilities of the environment. The pin material is typically brass but for greater electrical conductivity and more efficient heat dissipation tellurium copper is also available.

Please contact the technical support team to discuss your particular applications.

For more information, please visit www.mill-max.com/PR673.

MALE PCB PINS

PRINTED CIRCUIT PINS

5920

5920-0-00-XX-00-00-03-0

Solderless press-fit pin for plated through-hole
Recommended drilled hole size: .086 (2,18mm)

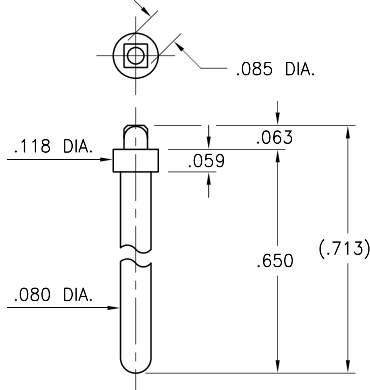

6025

6025-0-00-XX-00-00-03-0

Solderless press-fit pin for plated through-hole
Recommended drilled hole size: .068 (1,73mm)

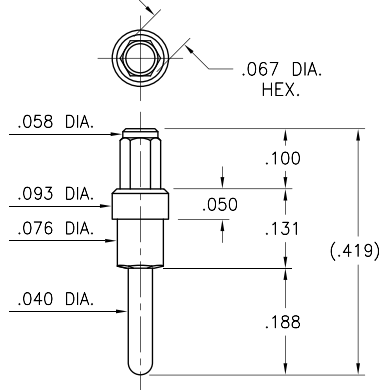

6035

6035-0-00-XX-00-00-03-0

Solderless press-fit pin for plated through-hole
Recommended drilled hole size: .068 (1,73mm)

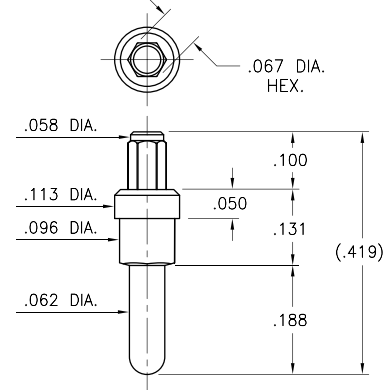

8237

8237-0-05-XX-00-00-03-0

Solderless press-fit pin for plated through-hole
Recommended drilled hole size: .092 (2,34mm)

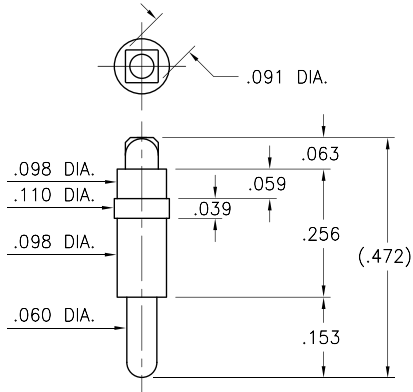

6834

6834-0-00-XX-00-00-03-0

Solderless press-fit pin for plated through-hole
Recommended drilled hole size: .0512 (1,3mm)

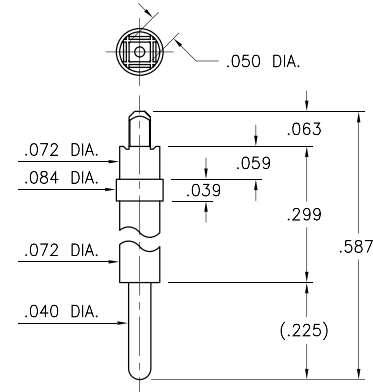

6835

6835-0-00-XX-00-00-44-0

Solderless press-fit pin for plated through-hole
Recommended drilled hole size: .092 (2,34mm)
* Pin Material: Tellurium Copper Alloy

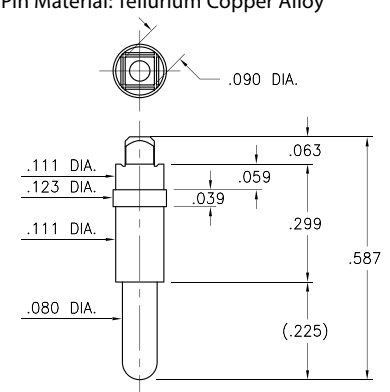

Recommended drilled hole sizes are prior to plating of the PCB and based on typical copper deposition of .5 - 1 oz. This results in a reduction of hole size by approximately .0015" - .003". Depending on surface plating, typical finished hole sizes are .003" - .005" smaller than drilled hole sizes. The finished hole size tolerance for press-fit applications should be specified as +/- .002"

SPECIFICATIONS:

Pin Material: Brass Alloy 360, 1/2 Hard
(Except where noted) *

Dimensions: Inches

Tolerances On: Lengths: ±.005
Diameters: ±.002
Angles: ± 2°



ORDER CODE: XXXX - 0 - 0X - **XX** - 00 - 00 - XX - 0

BASIC PART # →

→ **SPECIFY PIN FINISH:**

- 01 200 μ" TIN/LEAD OVER NICKEL
- ◆ 80 200 μ" TIN OVER NICKEL (RoHS)
- ◆ 15 10 μ" GOLD OVER NICKEL (RoHS)
- ◆ 21 20 μ" GOLD OVER NICKEL (RoHS)
- ◆ 34 50 μ" GOLD OVER NICKEL (RoHS)

