

Introducing the *PSB*— Push Spacer on Adhesive Base

Features and Benefits

- Sturdy construction supports heavily loaded PCB's
- Natural color Nylon 6/6 available in UL94 V2 and UL94 V0
- 6 standoff heights available
- 0.701" (17.8mm) square footprint with an easy-release tab on the adhesive
- Allows easy access to underside of the PCB

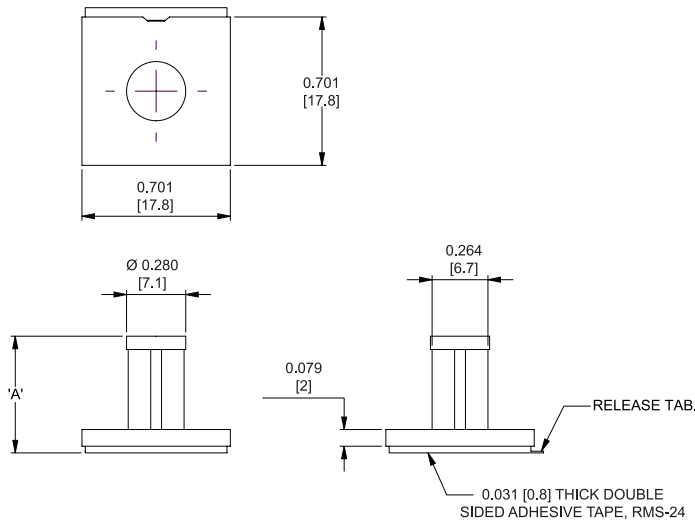
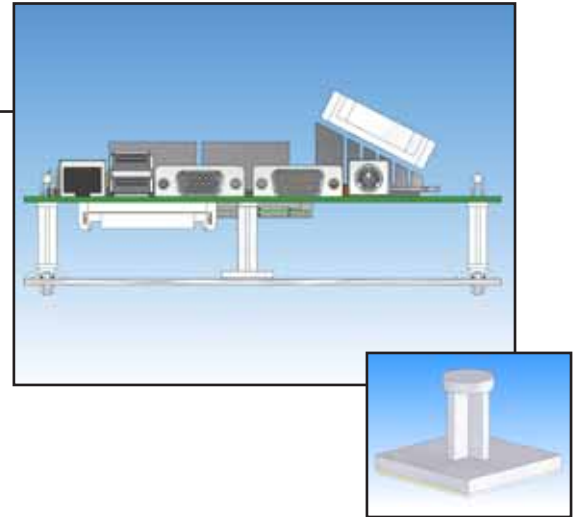

Markets

- Consumer Electronics
- Industrial Electronics
- White Goods
- Brown Goods
- Control Panels

Other Related Richco Product Solutions



PST



CPST

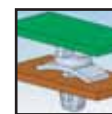

PS



PSM



PSC



RLCBSRS

PSB	Standard Pack: 1,000 per bag
Material: UL94 V2 Nylon 6/6, RMS-01* Color: Natural	"A" ± 0.015 (0.4)
PSB-6M-01A2-RT	0.236 (6)
PSB-8M-01A2-RT	0.314 (8)
PSB-10M-01A2-RT	0.393 (10)
PSB-12M-01A2-RT	0.472 (12)
PSB-14M-01A2-RT	0.551 (14)
PSB-16M-01A2-RT	0.629 (16)
*Also available in UL94 V0 material. To order, replace -01 with -19.	