

Introducing the *FSR*— Foot, Snap Rivet Mounted

Features and Benefits

- Rubber foot provides skid and shock resistance and vibration control
- Easily mounted by locating the rivet into the hole, and pressing on the rubber rivet head
- No assembly hardware required
- Three rivet sizes allow for mounting into panel thicknesses from .047 - .138 (1.2 - 3.5mm)
- Two head styles

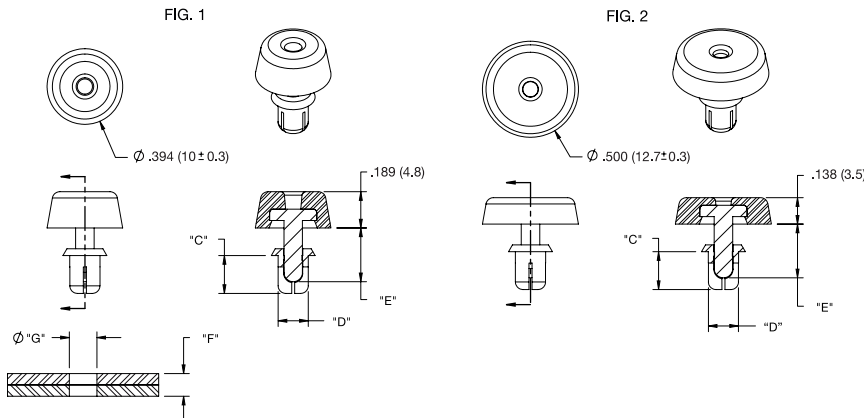
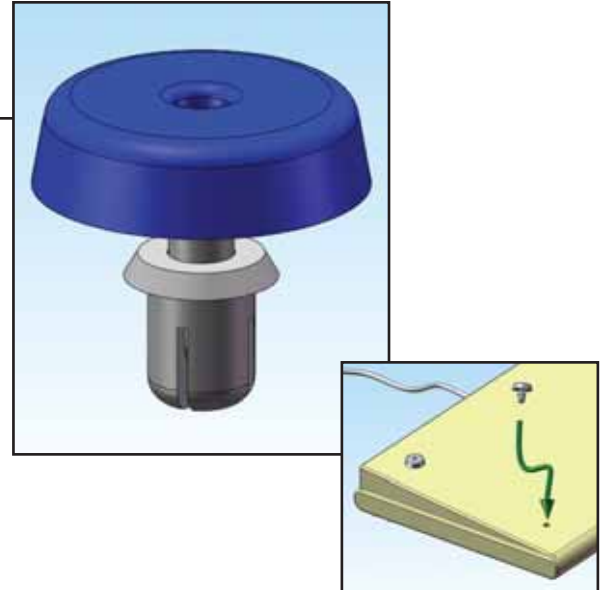

Markets

- General Electronics
- Medical Equipment
- Furniture
- Consumer Electronics
- Office Equipment

Material: Rivet: UL94 V2 Nylon 6, RMS-52 Foot: TPE, RMS-351, Color: Black						
Standard Pack: 1,000 per bag						
Part No.	"G" Hole Diameter	"F" Panel Thickness	"C" ± 0.3 mm	"D"	"E" ± 0.3 mm	Figure
FSR-1	.142-.146 (3.6-3.7)	.047-.083 (1.2-2.1)	.138 (3.5)	.138 (3.5)	.201 (5.1)	1
FSR-2	.142-.146 (3.6-3.7)	.083-.118 (2.1-3)	.177 (4.5)	.138 (3.5)	.240 (6.1)	
FSR-3	.161-.165 (4.1-4.2)	.098-.138 (2.5-3.5)	.197 (5)	.157 (4)	.280 (7.1)	
FSR-4	.142-.146 (3.6-3.7)	.047-.083 (1.2-2.1)	.138 (3.5)	.138 (3.5)	.201 (5.1)	2
FSR-5	.142-.146 (3.6-3.7)	.083-.118 (2.1-3)	.177 (4.5)	.138 (3.5)	.240 (6.1)	
FSR-6	.161-.165 (4.1-4.2)	.098-.138 (2.5-3.5)	.197 (5)	.157 (4)	.280 (7.1)	

Other Related Richco Product Solutions

