

Introducing the *FTH-31* Edge Clip Tie Holder

Features and Benefits

- Simply push the clip onto the edge of a panel to accept a cable tie and to mount a cable bundle
- Clip accepts many different size ties, and the tie can be mounted in two directions
- Plastic housing with assembled metal clip provides strong retention to the panel
- The holder accepts panels of 0.03" - 0.12" (0.8mm - 3mm)
- There are no panel holes necessary, saving in real estate on the board
- Edge clip is available in three plastic materials: UL94 V2 Nylon 6/6, UL94 V0 Nylon 6/6, and High Temperature Nylon 4/6

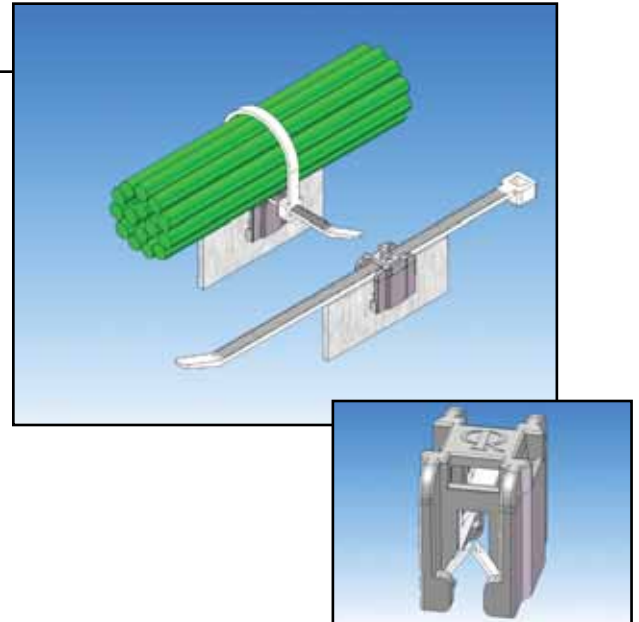
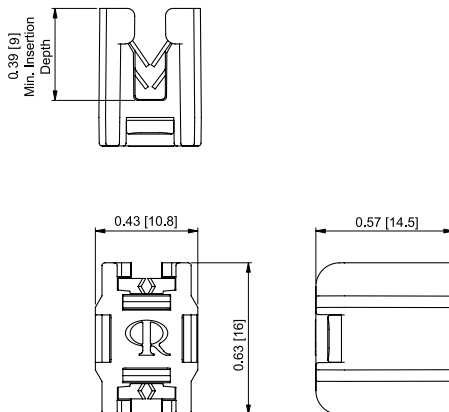

Markets

- White Goods
- Consumer Electronics
- Industrial Electronics
- Harness Manufacturers
- Automotive
- PCB Assemblers

| Material: Metal Clip: Stainless Steel, RMS-365 Grade 304 (1.4301mm thick) Color: Type 2B Bright Finish; Plastic Housing: UL94 V2 Nylon 6/6, RMS-01 Color: Black | | | |
|--|--------------------------|--|---|
| Part Number | Panel Thickness | Retention Force | Cable Ties Accepted |
| FTH-31-01 | 0.03 - 0.12 (0.8 - 3) | To Steel Panel: Minimum 25N 0.03 (0.8) Panel; Minimum 45N 0.12 (3) Panel | WITE/WIT-30, -40, -50; QTE-18, -30, -50 |
| | | To Plastic Panel: Minimum 150N 0.09 - 0.12 (2.4 - 3) | |
| Can Be Assembled With Cable Ties By Special Order | | | |
| Housing also available in UL94 V0 Nylon 6/6, RMS-19 and UL94 V2 Heat Stabilized Nylon 6/6, RMS-47 by special order. To order, replace -01 with -19 or -47, respectively. | | | |

Other Related Richco Product Solutions



FTH-1-01



FTH-24-01



FTH-30-01



FTH-9-01



FTH-5A-RT



FTH-6-01