

Introducing the **WIT-3ORCA**

Releasable Cupped Cable Ties

Features and Benefits

- One piece design saves time and costs associated with inventory and assembly
- Simply press the cable tie into the pre-drilled chassis hole at any point along the assembly process
- Cupped arrowhead provides for a range of panel thicknesses from .023 - .098 (0.6 - 2.5) as well as giving more stability in the chassis mount
- The cup covers the hole and can provide protection against contamination
- Cable ties are available in a variety of materials, UVB Stabilized, Heat Stabilized, UL94 V0 and standard UL94 V2 Nylon 6/6

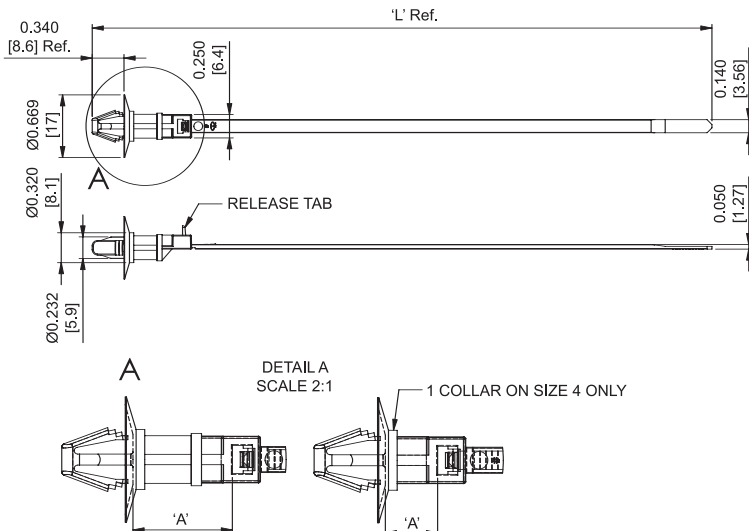
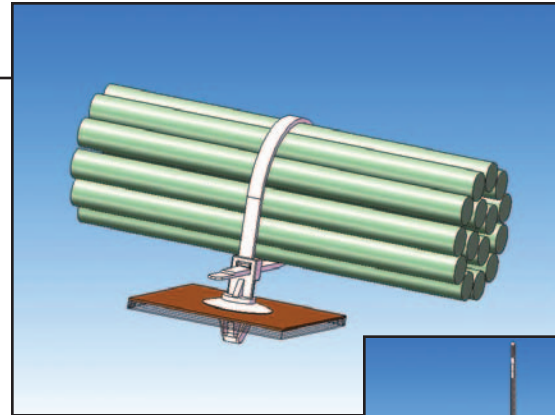

Markets

- White Goods
- Brown Goods
- Medical
- Security

Other Related Richco Product Solutions



WIT-30RRA



WIT50-RLA



WIT

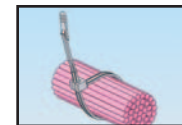

QTE

Material: Nylon 6/6, RMS-01* Color: Natural			Standard Pack: 1,000 per bag			
Part No.	L Ref.	A	Min. Loop Tensile Strength lb. (kg.)	Bundle Diameter	Hole Diameter	Panel Thickness
WIT-30RCA-4-M	6.326 (160.7)	0.279 (7.1)	30 (13)	1.250 (31.8)	Ø 0.236 - 0.255 (6 - 6.5)	0.023 - 0.098 (0.6 - 2.5)
WIT-30RCA-8-M	6.625 (168.3)	0.531 (13.5)				
WIT-30RCA-12-M	6.847 (174.6)	0.779 (19.8)				
WIT-30RCA-16-M	7.094 (180.2)	1.00 (25.4)				

*Also available in UV Stabilized Material (RMS-46 Black), Heat Stabilized Material (RMS-47 Black), and UL94 V0 Nylon (RMS-19 Natural). To order, add -UVB, -HS, or -V0 before the -M in the part number, respectively.