

Introducing the **FMB**— Fan Mount, Breakaway Style

Features and Benefits

- Elastomeric, evenly spaced ribs for mounting fans of many different heights
- Pull-through, breakaway installation tabs ease assembly, especially in blind corners
- Pull-tab breaks away cleanly after installation for low profile panels
- Fits Industry Standard DC Fans with a wide range of hole sizes and panel thickness
- Noise and vibration reduction
- Reduces the number of hardware for the assembly

Fan Hole: FMB-1, .13 to .14 (3.2 to 3.5)
 FMB-2, .16 to .18 (4 to 4.5)
Fan Thickness: FMB-1, .39 to .98 (10 to 25)
 FMB-2, .98 to 2.01 (25 to 51)

Fig. 1

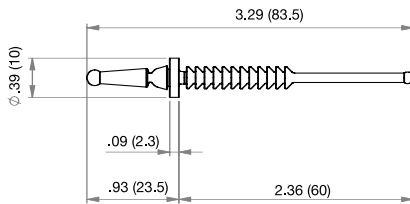
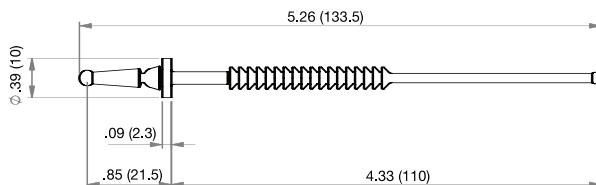
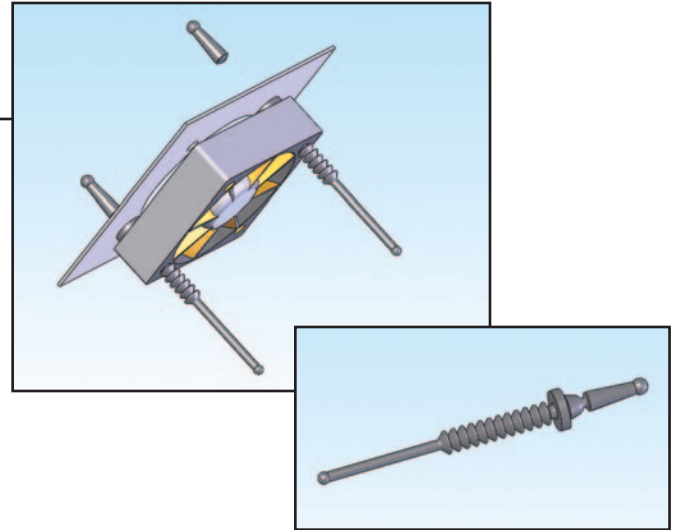

Fig. 2



Panel Hole: FMB-1, .18 to .20 (4.5 to 5)
 FMB-2, .03 to .06 (.8 to 1.6)
Panel Thickness: .03 to .06 (.8 to 1.6)

- ASSEMBLY PROCEDURE:**
- STEP 1: PULL MOUNT TO PANELGRIP BREAKS-AWAY AFTER FIXING
 - STEP 2: LOCATE AND ASSEMBLE FAN HOUSING



Markets

- Office Equipment
- Consumer Electronics
- Telecommunications
- Industrial Electronic Appliances
- White Goods

Other Related Richco Product Solutions

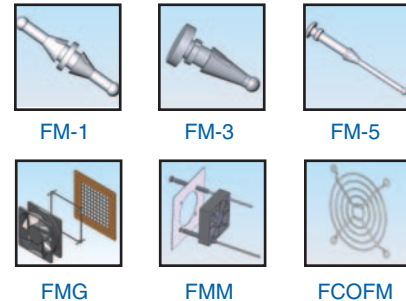

**Material: Silicone Rubber 40 Shore A,
 RMS-316**

Standard Pack: 1,000 per bag

Part No.	Fig.
FMB-1	2
FMB-2	1