

Introducing the **FTH-30**— Cable Tie Holder

Features and Benefits

- Has the same mounting head as a cable tie
- Allows bundle with pre-assembled cable tie to be held in place
- When tail end of the cable tie is inserted, the tie holder locks it into place
- Can be used as a standard tie holder, using ties that are not pre-assembled
- Holds all Richco WIT-18 series cable ties
- Holder is easily installed in panel; simply snap in place

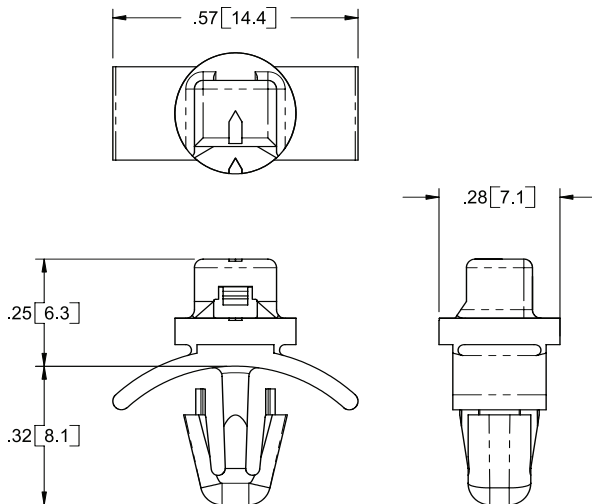
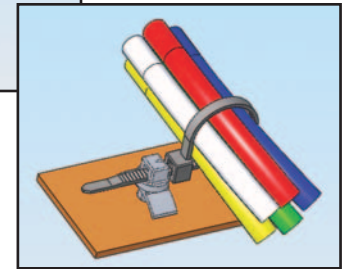
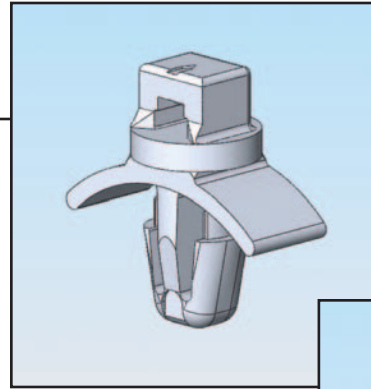

Markets

- Consumer Electronics
- Appliance
- Telecommunications
- Electrical

Other Related Richco Product Solutions

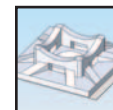

FTH-7A-RT

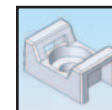

FTH-13R

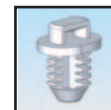

FTH-15

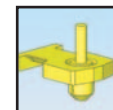

FTH-22



FTH-29

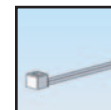

WIT-18

Material: Nylon 6/6, RMS-01* Color: Natural			
Part No.	Standard Pack: 1,000 per bag		
	Hole Diameter	Panel Thickness	Accepts Cable Ties
FTH-30-01	.187 ± .003 (4.76 ± 0.08)	.031 - .078 (0.79 - 1.98)	WIT-18

*Parts are available in UL94 V0 material by special order only. To order, replace -01 with -19.